



Cert. No. LRQ 0963008

ISO 9001

spirax sarco

BVA200 Series Pneumatic Actuator with M10V or M10S Ball Valve

Selection tables

How to choose:

Ball valve and actuator tables for operating air pressure of 4, 5, or 6 bar g.

Key: Light service (LS), Heavy service (HS), Double acting (D), Single acting with return spring (S),
Reduced bore (RB), Full bore (FB).

Operating pressure: 4 bar g

Valves M10V and M10S Size	BVA_ actuator			
	Double acting		Single acting	
	LS	HS	LS	HS
¼" RB - ¾" RB	210D	210D	210S/4	210S/4
½" RB - ¾" FB	210D	210D	215S/4	215S/4
¾" RB - ½" FB	210D	210D	215S/4	215S/4
1" RB - ¾" FB	215D	215D	220S/4	220S/4
1¼" RB - 1" FB	215D	220D	220S/4	220S/4
1½" RB - 1¼" FB	220D	220D	220S/4	225S/4
2" RB - 1½" FB	220D	225D	225S/4	230S/4
2½" RB - 2" FB	225D	230D	230S/4	235S/4

Operating pressure: 5 bar g

Valves M10V and M10S Size	BVA_ actuator			
	Double acting		Single acting	
	LS	HS	LS	HS
¼" RB - ¾" RB	210D	210D	210S	210S
½" RB - ¾" FB	210D	210D	210S	210S
¾" RB - ½" FB	210D	210D	215S	215S
1" RB - ¾" FB	215D	215D	220S	220S
1¼" RB - 1" FB	215D	215D	220S	220S
1½" RB - 1¼" FB	215D	220D	220S	220S
2" RB - 1½" FB	220D	220D	225S	225S
2½" RB - 2" FB	225D	225D	230S	235S

Operating pressure: 6 bar g

Valves M10V and M10S Size	BVA_ actuator			
	Double acting		Single acting	
	LS	HS	LS	HS
¼" RB - ¾" RB	210D	210D	210S	210S
½" RB - ¾" FB	210D	210D	210S	210S
¾" RB - ½" FB	210D	210D	210S	210S
1" RB - ¾" FB	210D	215D	215S	215S
1¼" RB - 1" FB	215D	215D	215S	220S
1½" RB - 1¼" FB	215D	215D	220S	220S
2" RB - 1½" FB	220D	220D	220S	225S
2½" RB - 2" FB	220D	225D	225S	230S

BVL_ Linkage kit selection table

Valves M10V and M10S Size	Series 200 BVA_ actuator							
	210	215	220	225	230	235	240	245
¼" RB - ¾" RB	240							
½" RB - ¾" FB	241	241						
¾" RB - ½" FB	242	242						
1" RB - ¾" FB	243	243	244					
1¼" RB - 1" FB		245	246					
1½" RB - 1¼" FB		247	248	248				
2" RB - 1½" FB			249	249	249			
2½" RB - 2" FB			250	250	250	251		

Note: Linkage Kits BVL240-S to 251-S for M10 stainless steel are available upon request.

Conditions

Light service (LS)

- Clean, low viscosity fluid, without solids in suspension.
- Maximum saturated steam pressure 3 bar g.
- Maximum working temperature 143°C at 10 bar g.
- Maximum differential pressure 20 bar g at 38°C.
- Frequent operation.

Heavy service (HS)

All those applications where at least one of the above mentioned conditions is exceeded.

Example

Select an actuator and linkage kit for the following application:

Valve required: 1½" screwed BSP M10S2FB ball valve.

Available air pressure: 6 bar g.

Light service, double acting actuator.

1. Select from 6 bar g operating pressure table an actuator for a 1½" FB ball valve, light service (LS), double acting: **BVA220D**
2. Select from BVL linkage kit selection table a BVL suitable for a 1½" FB ball valve and BVA220 actuator: **BVL249**

How to order

Example: 1- Spirax Sarco 1½" screwed BSP M10S2FB ball valve, with BVA220D actuator and BVL249 linkage kit, operating with 6 bar g air pressure.

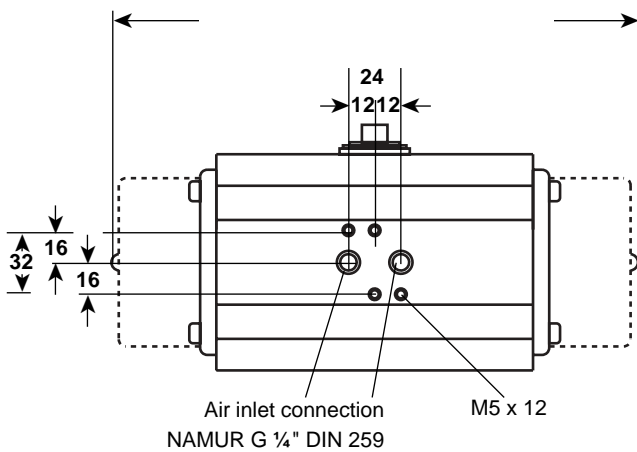

Dimensions/weights (approximate) in mm and kg

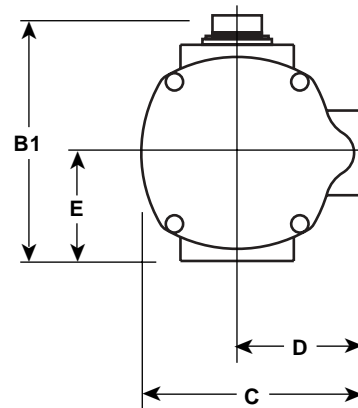

BVA200 Series actuators

Type	A		B1	C	D	E	Actuator weight	
	Double acting	Single acting					Double acting	Single acting
BVA210	130	215	96	76	48	34	1.1	1.5
BVA215	144	232	115	90	56	45	1.7	2.3
BVA220	162	270	137	111	66	55	2.6	4.0
BVA225	182	297	146	121	71	60	3.4	5.5
BVA230	211	332	165	135	78	70	5.1	8.4
BVA235	245	371	182	151	86	80	7.6	12.1
BVA240	275	420	199	172	96	85	10.5	16.5
BVA245	336	474	217	192	106	98	16.0	24.0
BVA250	420	578	249	212	116	114	26.0	38.0
BVA255	462	614	280	242	131	131	36.5	52.0

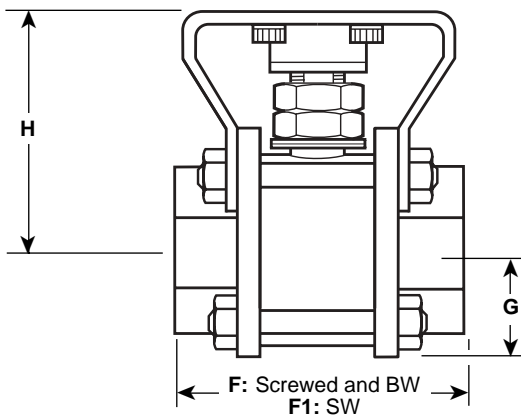

Linkage kit description

BVL Linkage kit components and materials are as follows

Frame (1)	Zinc plated carbon steel
Stem adapter (1)	Zinc plated carbon steel
Frame-to-actuator screws (4)	Zinc plated carbon steel Gr. 5
Valve bolts (2)	Zinc plated carbon steel Gr. 5
Nuts (2)	Zinc plated carbon steel Gr. 5
Stem nuts (2)	Zinc plated carbon steel Gr. 5
Washers (4)	Zinc plated carbon steel

BVL linkage kit with M10V or M10S ball valve

Reduced bore

Size	F	F1	G	H	Weight (Valve)
1/4"	56	52	22	44	0.45
3/8"	56	52	22	44	0.45
1/2"	63	52	24	47	0.57
3/4"	68	60	26	49	0.70
1"	86	84	31	64	1.27
1 1/4"	99	94	37	69	1.77
1 1/2"	108	102	41	83	2.50
2"	124	118	48	90	3.50
2 1/2"	152	152	57	133	6.90

Full bore

Size	F	F1	G	H	Weight (Valve)
1/4"	56	58	22	44	0.45
3/8"	63	60	24	47	0.57
1/2"	68	64	26	49	0.70
3/4"	86	84	31	64	1.27
1"	99	98	37	69	1.77
1 1/4"	108	106	41	83	2.50
1 1/2"	124	124	48	90	3.50
2"	152	152	57	133	6.90

Note: Weights including BVL are available upon request.