

Syphon for pressure gauges DIN 16 282

syphons U-shaped for horizontal pressure tapping

Design A (similar to DIN 16 282)
with male thread on process side

Design B
with weld end on process side

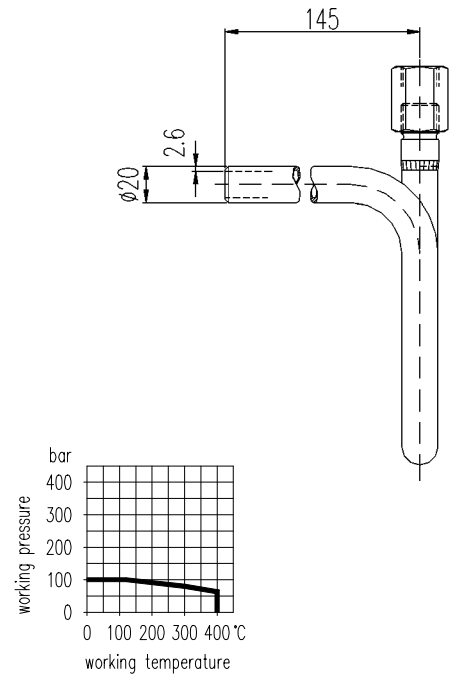
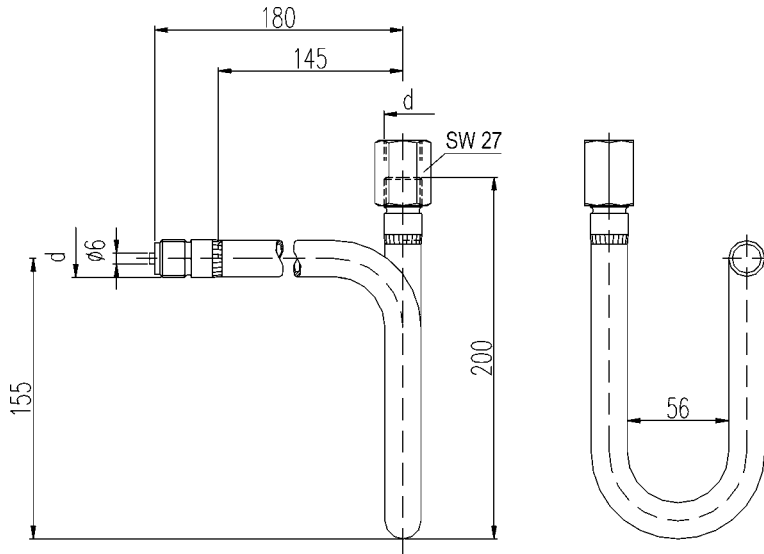

Connection thread d	Material	Part no.	
		Design A	Design B
G 1/2	Steel	15-SIP02-A-SC-51	15-SIP02-B-SC-51
	St. st.	15-SIP02-A-SS-51	15-SIP02-B-SS-51
½ NPT	Steel	04-SIP02-A-SC-50	04-SIP02-B-SC-50
	St. st.	04-SIP02-A-SS-50	04-SIP02-B-SS-50

Material		max. working pressure bar	max. working temperature in front of the water syphon °C
Abbreviation			
10 St	St 35.8	100	120
20 St	316Ti (1.4571)	80	300
		63	400

Components	Steel	Stainless steel
	DIN-Material Number	
Tube 20 x 2,6 mm	St 35.8	316Ti (1.4571)
Male connector	Ck 15	316Ti (1.4571)

- Surface: steel phosphatized
- Range of application:
For liquids, gas or steam
- Other materials, pressure/temperature ratings and connections on request